

ALFA  
LIVING

### SCHEDA TECNICA

forno a legna  
BRAVO

FXBRAV-LGRI

diamond  
grey



**Materiali utilizzati:** lamiera ferro, acciaio inox, fibra ceramica  
**Tipo di refrattario:** tavella silico-alluminoso  
**Combustibile raccomandato:** ciocchi diam. max 5 cm, potature

**Used material:** iron sheet, stainless steel, ceramic fiber  
**Type of refractory:** Alumina silicate bricks  
**Recommended fuel:** max 1,9 in diam. logs, trimmings

### Dettagli tecnici / Technical details

<b>Peso</b> <i>Weight</i>	185 kg 408 lbs	<b>Carica nominale</b> <i>Rated charge</i>	8,3 kg/h 18,3 lbs/h
<b>Area piano forno</b> <i>Oven floor area</i>	0,42 m <sup>2</sup> 4,52 ft <sup>2</sup>	<b>Consumo medio</b> <i>Average fuel consumption</i>	4 kg/h 8,8 lbs/h
<b>Dim. piano forno</b> <i>Oven floor dim.</i>	70 x 60 x 5,4 cm 28 x 24 x 2,1 in	<b>Tiraggio minimo</b> <i>Minimum flue draught</i>	11 Pa
<b>Minuti per scaldare</b> <i>Heating time (min)</i>	25	<b>Flusso volumetrico fumi</b> <i>Flue smokes mass flow</i>	49,6 g/s
<b>N° pizze alla volta</b> <i>Pizza capacity</i>	3	<b>Emissioni CO al 13% O<sub>2</sub></b> <i>CO emission at 13% O<sub>2</sub></i>	0,35% 4444 mg/Nm <sup>3</sup>
<b>Infornata di pane</b> <i>Bread capacity</i>	4 kg 8,8 lbs	<b>Temperatura fumi</b> <i>Smoke temperature</i>	387 °C 728 °F
<b>Temperatura massima</b> <i>Max oven temperature</i>	400°C 752°F	<b>Anno di produzione</b> <i>Production year</i>	2016

## Misure / Dimensions

<b>A</b>	243,3 cm	95,8 in
<b>B</b>	161,4 cm	63,5 in
<b>C</b>	55,0 cm	21,7 in
<b>D</b>	99,9 cm	39,4 in
<b>E</b>	21,6 cm	8,5 in
<b>F</b>	18,0 cm	7,1 in
<b>G</b>	81,4 cm	32,0 in
<b>H</b>	110,0 cm	43,3 in
<b>I</b>	114,2 cm	45,0 in

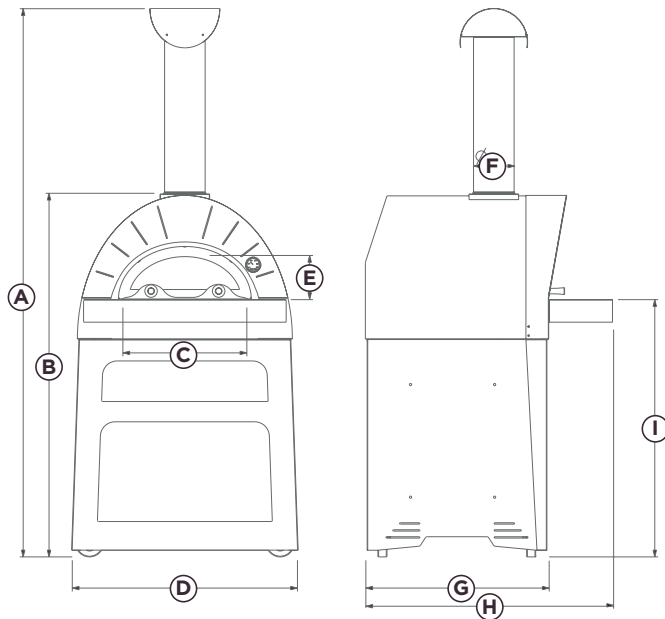

## Lista componenti / Assembly part list

CODICE	N°	DESCRIZIONE
<b>a</b>	SBRV-01-027	1 comignolo cpl
<b>b</b>	TI_180_750_SAT	1 tubo inox aisi 304 d.180mm l:750 satinato monob. (solo lav.)
<b>c</b>	SBRV-01-033	1 flangia inox
<b>d</b>	SBRV-01-020	1 arco inox cpl
<b>e</b>	SBRV-01-002	1 camera comb cpl
<b>f</b>	ACPAR-AL45	1 paralegna alto da 45 cm
<b>g</b>	SBRV-01-045	1 sportello forno cpl
<b>h</b>	SBRV-01-030	1 davanzale inox cpl
<b>i</b>	SBRV-01-035-GR	1 base cpl verniciato grigio forno bravo
<b>j</b>	SFRU-01-125	1 fermo ruota d. 125
<b>k</b>	SBRV-01-016-GR	1 carter est cpl verniciato grigio argento forno bravo
<b>l</b>	YT63-190	1 termometro d.63 l.190 mm - °C / °F
<b>m</b>	INNA125OFIO	4 ruote

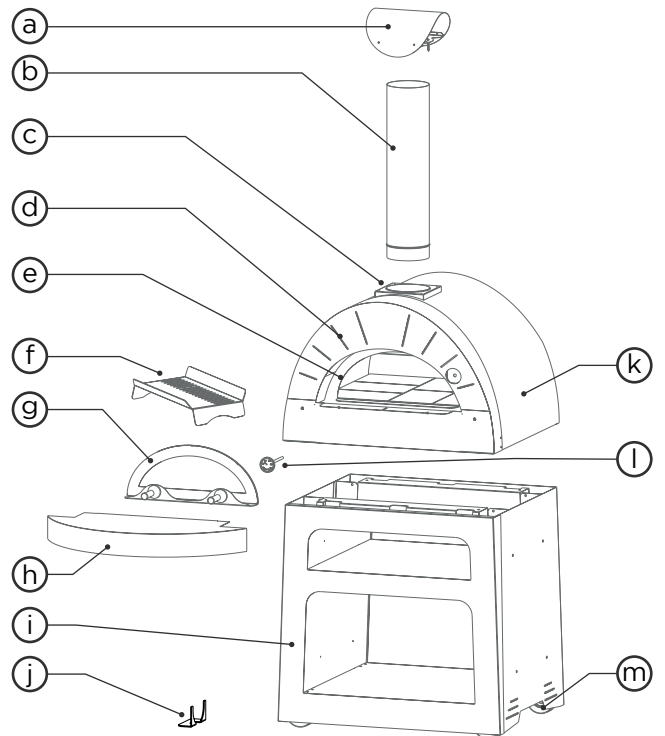

## Misure imballo / Packaging dimensions

<b>H</b>	175 cm	68,9 in
<b>W</b>	110 cm	43,3 in
<b>D</b>	100 cm	39,4 in
<b>Peso</b>	295 Kg	<b>Weight</b> 650 lbs

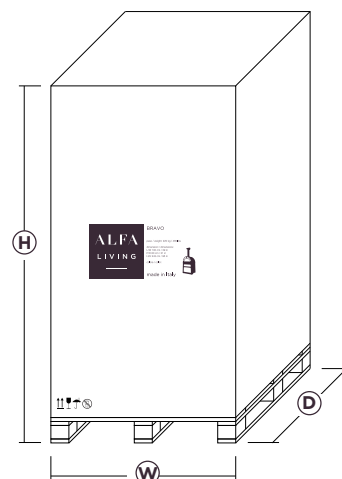

**Materiali di confezionamento:** cartone doppia onda, termoretraibile.

**Packaging material:** cardboard box, shrink wrap.